

# THE BAKER COMPANY

*Designed to Handle Hazardous Microbiological Agents or Pharmaceutical Potent Compounds Under Contained Conditions.*

## **IsoGARD®** **Class III Glovebox**



*The IsoGARD® Model IG-14 glovebox, shown with optional hinged front viewscreen closed and locked, and optional dunk tank (right).*

### **IsoGARD® Class III Glovebox**

The Baker Company IsoGARD® series Class III glovebox is designed for research involving agents assigned to BSL-3 and -4 facilities, or where a very high level of containment is required because of the nature of the protocol. The cabinets are designed to allow safe handling of hazardous microbiological agents or pharmaceutical potent compounds under contained conditions. The IsoGARD®

meets the very stringent performance, construction and leak-testing requirements of Class III biological safety cabinetry, as defined by the U.S. Federal Register.

### **The State of the Art in High Containment**

IsoGARD® Class III safety cabinets represent a considerable advance over previously available high-containment equipment and represent more than 50 years of experience in the design

and manufacture of gloveboxes, pharmaceutical isolators and Class II biological safety cabinets. Now this collective knowledge has been applied to our latest line of IsoGARD® Class III gloveboxes to offer the maximum level of product, personnel and environmental protection.

*An optional top hinged viewscreen allows full opening for loading of instrumentation or equipment.*

**Personnel protection**, of utmost importance for

Class III applications, is accomplished by placing a primary physical barrier between the laboratory investigator and the biological agent. Gas-tight construction and utilization of a pass-thru chamber to move materials into and out of the main cabinet further ensures containment within the primary working area.

Baker's new design offers a degree of **product protection** higher than that achieved before in any Class III equipment. This is accomplished by mass displacement of the entire volume of air within the cabinet (rather than relying on dilution of cabinet air to provide cleanliness). The IsoGARD® bathes the interior of the cabinet with HEPA-filtered air, thereby increasing entrainment of generated particles and keeping the work area free of contaminants.



**Environmental protection** is provided by Baker's exclusive "plug-and-seal" canister-style HEPA exhaust filters. All exhaust air is passed through the filters before being removed by the facility exhaust, thus protecting laboratory personnel and others from potential particulate exposure.

Additionally, IsoGARD® **ergonomic features** make for a glovebox that is much more comfortable to work in than those of the past. These include oval gloveports mounted directly into the 10° tilted viewing window, exhaust plenums located away from a sitting operator's knees and external light canopies positioned above the user's head.



The IsoGARD® glovebox, Model IG-12.

### General Design and Performance Features

The IsoGARD® is particularly well-suited for aerosolization studies, vaccine research, handling of sterile potent pharmaceutical compounds and inspection of unknown suspected terrorism samples.

- The IsoGARD® is designed in three standard models that offer two-, three- and four-glove primary working chambers along with a host of options that allow users to tailor a cabinet to meet most standard requirements.

- The IsoGARD® glovebox includes an integral, full-size HEPA-filtered pass-thru chamber with a unique space saver front-opening glass panel door that allows users to introduce samples into the main working chamber with ease. A built-in gloveport allows the user to manually wipe down and clean the interior of the pass-thru as well as aid in the manipulation of samples.

- IsoGARD® units are equipped with full-coverage, ceiling-mounted supply HEPA filters to ensure an ISO Class 4 (FS209E Class10) operating environment, as well as easily removable, specially designed cartridge-style exhaust HEPA filters to provide environmental protection.

- Cabinets operate continually under a negative 0.5 inch water column pressure to ensure continued personnel protection in the event of a glove or seal failure.

- Baker's Class III gloveboxes are built to the highest leak-tightness specifications to ensure the safety of laboratory workers. Each IsoGARD® is factory-tested using a Class III Sulfur Hexafluoride (or equivalent helium) leak test prior to shipping. An SF<sub>6</sub> leak rate no greater than  $5 \times 10^{-7}$  cc/sec at 3 inches positive water column pressure is the acceptance criteria. The equivalent helium acceptance requirement is  $1.5 \times 10^{-5}$  cc/sec at 3 inches positive water column pressure (33% helium).

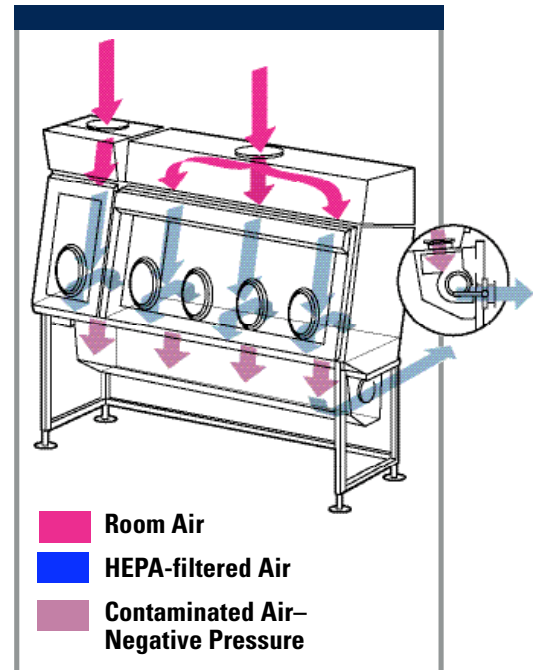

### Caution:

The adequacy of this glovebox for the user's personal safety, as with any Class III glovebox, should be determined by an industrial hygienist or safety officer.

IsoGARD® maximum containment gloveboxes are commonly used in Biosafety Level (BSL) 3 and 4 laboratories. Applications include vaccine research, infectious disease diagnostic procedures and research, processing suspected terrorism samples (chemical and biological) and handling potent pharmaceutical compounds in an aseptic environment.

## High-Containment Design

The IsoGARD® is designed to provide the highest level of protection for work with high-risk agents and potent compounds.

- Baker's exclusive "plug-and-seal" canister-style HEPA exhaust filters allow for the safe and convenient changing of loaded filters without expensive bag-in/bag-out housings.
- Pass-thru and main chamber incorporate unidirectional airflow to flush away any generated particles while bathing the work surface in HEPA-filtered air.
- The IsoGARD® operates continuously at a negative 0.5 inch water column pressure for maximum personnel and product protection.
- Gas-tight doors and viewscreens maintain air conditions internally. Baker tests the IsoGARD® to ensure leak-tightness to Class III standards.

## Cabinet Construction Enhances Performance

The IsoGARD® uses heavy 11-gauge, 316L-type stainless steel construction with easy-to-clean, fully welded and polished radius corners to prevent buildup of contaminants and resist corrosion. There are no bolt-on end panels to collect contamination.

- The IsoGARD® is constructed with thick safety glass, solid closed-cell silicone gaskets and is supplied with neoprene gloves.
- Baker polishes the IsoGARD® surfaces to a non-glare satin finish. Large radius corners facilitate easy cleaning to help prevent corrosion and buildup of contamination.
- The stainless steel work surface is dished to contain spills.

## Ease of Maintenance Minimizes Downtime

Several IsoGARD® design features combine to make required maintenance and service easy and safe, thus reducing downtime.

- The IsoGARD® fits through standard doorways without disassembly, making installation simple.
- Easy-to-clean radius corners help prevent buildup of contaminants.
- Locking stainless steel ball valve allows efficient drainage of liquids.
- Baker's exclusive "plug-and-seal" canister-style HEPA exhaust filters allow for the safe and convenient changing of loaded filters.
- External micro-bulb light assembly provides 75 foot-candles of illumination to the work surface and is serviceable from outside the IsoGARD® to maintain product and personnel protection during maintenance.
- Stainless steel gloveport design with one-piece sleeve-and-glove assembly allows gloves to be replaced or changed without breaking containment.

## IsoGARD® Design and Performance Features

- 1 Exclusive "plug-and-seal" canister-style HEPA exhaust filters provide environmental protection.
- 2 Full-size, HEPA-filtered pass-thru chamber.
- 3 Supply HEPA filter, protected with 316L stainless steel diffuser, covers the entire ceiling of the primary working chamber.
- 4 3/8" mirror-quality safety glass viewscreen provides maximum safety and reduces eye fatigue.
- 5 Viewscreen sloped 10° for the most comfortable head and elbow position.
- 6 Stainless steel gloveports with single-piece sleeve-and-glove assembly.
- 7 External micro-bulb light assembly provides 75 foot-candles of illumination to the work surface.
- 8 Tubular stand constructed from Type 304 stainless steel.
- 9 Digital pressure gauges, equipped with audible and visual alarms, monitor proper operating pressures.
- 10 Optional dunk tank allows materials to be surface-decontaminated and passed in and out of the glovebox without breaking containment.



## Ergonomic Design

The Baker Company offers an adaptive ergonomic design combined with a unique airflow management system and proven containment technology to improve comfort and increase productivity while assuring safety.

- The IsoGARD® slanted viewscreen is angled at 10° for optimum ergonomic comfort and safety.
- The 3/8" mirror-quality safety glass viewscreen provides maximum safety, reduces eye fatigue, is extremely scratch resistant and is impervious to most common decontamination agents.
- Stainless steel gloveports with one-piece sleeve-and-glove assembly are built directly into the viewscreen for improved visibility and ergonomics.
- Single-piece sleeve-and-glove assemblies are available in neoprene, hypalon and other materials by special order. Baker also can size the gloves to your specifications. Gloves are available in left, right and ambidextrous styles.
- In a standard configuration, the IsoGARD® is set up to accommodate a standing worker, but a laboratory stool may be used for extended operations.

## Electrical System

In order to power any electrical equipment that may be required by the investigator, the IsoGARD® primary working chamber is equipped with built-in outlets.

- Two internal duplex outlets are standard in the primary working chamber (115V, 60Hz). Duplex outlets are equipped with weather-proof covers. Additional outlets may be provided as an option.

- Cabinet powered by 115 VAC, 20 amps, 1-phase using supplied 12' power cord or a hard connection with supplied junction box.
- Also available with 220V, 50Hz outlets.

## Exhaust Requirements

The IsoGARD® standard configuration requires connection to your facility's HVAC system to maintain negative pressure and exhaust flow.

- A secondary building HEPA-filtered exhaust system is required to meet the requirements of a Class III installation.
- Building exhaust system must provide suction of negative 2.5 inch water column static pressure at the flow rates listed on page 5.
- Optional blower/motor packages are available for use when building static pressure is inadequate to overcome the internal operating pressure of the IsoGARD®. Contact The Baker Company for details.

## Controls

The control panel for the IsoGARD® is conveniently positioned to allow the operator to monitor and control the glovebox for optimal operating conditions.

- Built-in dual digital magnehelic gauges monitor proper operating pressures in both the pass-thru and main chambers.
- Audible and visual alarms alert the operator of potentially unsafe conditions.
- Easy-to-reach external switches control lights and power outlets.



*The Baker Company was commissioned by a customer to build a custom Class III containment line to handle research and work with a Biosafety Level 4 pathogen.*

## Custom-Engineered Solutions

The Baker Company designs and manufactures Class III gloveboxes and isolators to meet specific user applications. Unique requirements for aerosolization studies, vaccine research and handling hazardous biological or chemical agents are all projects that our Custom Engineered Products Division deals with on a routine basis. All equipment is manufactured and tested to exacting standards to assure the integrity of your research and safety.

Our applications engineers are always ready to discuss your unique requirements. Drawing on the company's past experiences with hundreds of special applications, we can often make specific recommendations in minutes as well as provide drawings and quotations.

Contact The Baker Company directly at 800-992-2537 for more information.

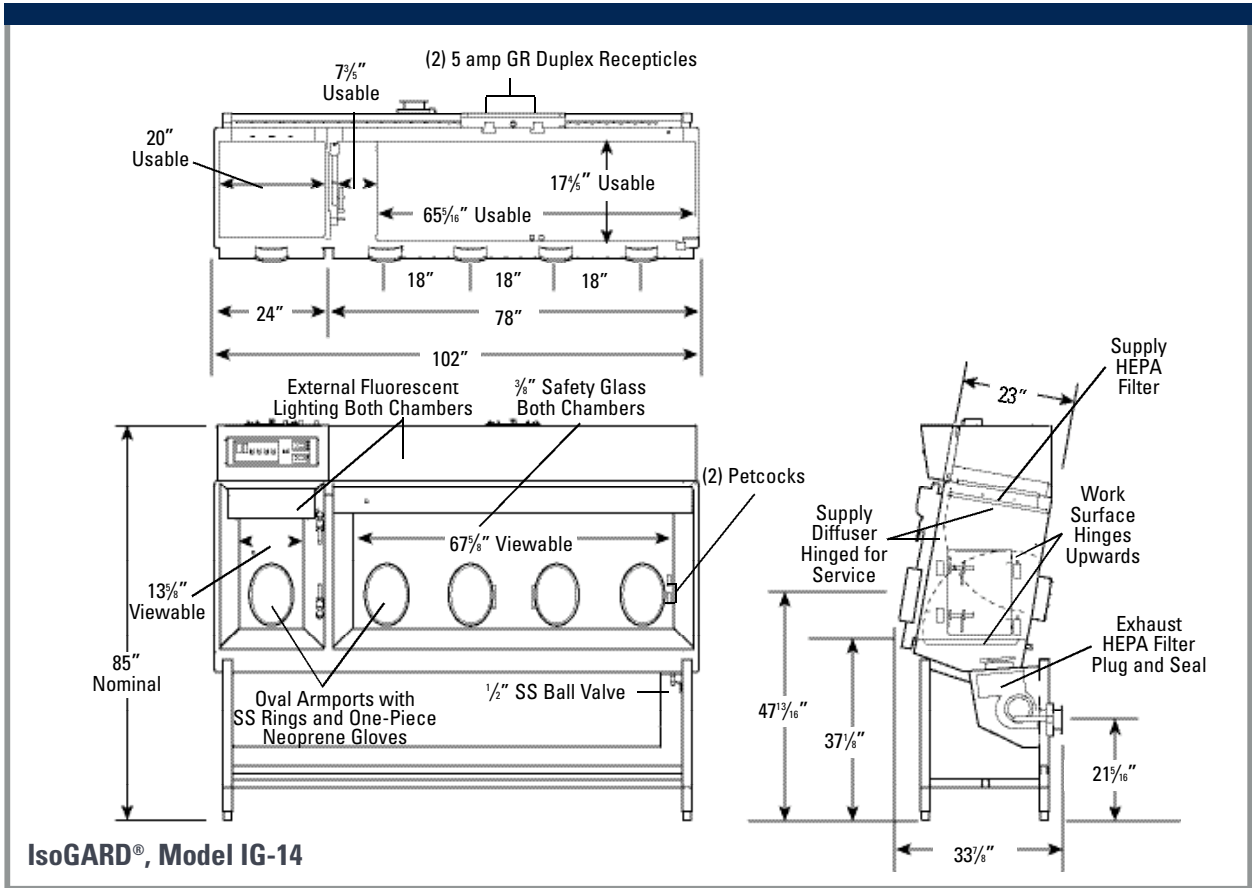

IsoGARD®, Model IG-14

**Options and Accessories**

- Disinfectant dunk tank
- Built in blower/motor
- Hinged gull-wing door on primary working chamber
- External decontamination ports
- Electronic door interlock

- Bag-in, bag-out exhaust HEPA filtration system with dual HEPA filters
- Butyl gaskets to replace standard silicone gaskets (for chemical containment)
- 220 VAC, 50Hz electrical system

**To Order**

For applications assistance and ordering information, terms and conditions of sale, contact The Baker Company direct toll-free USA (800) 992-2537 or (207) 324-8773. Or e-mail your request to bakerco@bakerco.com.

**Site Preparation\***

| Model                                   | IsoGARD® Model IG-14  | IsoGARD® Model IG-13  | IsoGARD® Model IG-12  |
|---|---|---|---|
| <b>Electrical System</b>                | 115 VAC, 20 amps, 1-phase using supplied 12' power cord or a hard connection with supplied junction box | 115 VAC, 20 amps, 1-phase using supplied 12' power cord or a hard connection with supplied junction box | 115 VAC, 20 amps, 1-phase using supplied 12' power cord or a hard connection with supplied junction box |
| <b>Exhaust Requirements</b>             | 350 CFM at negative 2.5" water column static  | 300 CFM at negative 2.5" water column static  | 250 CFM at negative 2.5" water column static  |
| <b>Glove/Working Chamber Dimensions</b> | 4-glove, 78" working chamber, 2' pass-thru  | 3-glove, 60" working chamber, 2' pass-thru  | 2-glove, 42" working chamber, 2' pass-thru  |

\*Note: Following installation, Class III equipment must be tested in place by a qualified 3rd party technician prior to use. Tests include tracer gas leak testing and other performance verification as recommended by the manufacturer.

## Purchase Specification

### IsoGARD® Class III Glovebox

- Manufacturer shall supply a certified copy of the factory Class III Sulfur Hexafluoride (or equivalent helium) leak test. An SF<sub>6</sub> leak rate no greater than  $5 \times 10^{-7}$  cc/sec at 3 inches positive water column pressure is the acceptance criteria. The equivalent helium acceptance requirement is  $1.5 \times 10^{-5}$  cc/sec at 3 inches water column positive pressure (33% helium).
- Exhaust filters shall be "plug-and-seal" canister-style HEPA filters.
- Full-size (nominal dimensions 24" x 24" x 29") pass-thru chamber shall include HEPA-filtered supply and exhaust and be equipped with a front-opening door, glass-viewing window and built-in armport.
- Each chamber shall incorporate unidirectional airflow to flush away any generated particulates while bathing the work surface in HEPA-filtered air.
- Supply HEPA filter shall have a full face, aluminum frame and gel-seal supply that covers the entire ceiling of the primary working chamber. Filter shall be protected with a 316L stainless steel diffuser.
- Cabinet shall operate continuously at a negative 0.5 inch water column pressure for maximum personnel and product protection.
- Cabinet shell shall be heavy 11-gauge, 316L-type stainless steel construction with easy-to-clean, fully welded and polished radius corners to prevent buildup of contaminants and resist corrosion. There shall be no bolt-on end panels to collect contamination.

- A 3/8" mirror-quality safety glass viewscreen sloped 10° shall be provided for maximum safety and comfort and reduced eye fatigue.
- Doors and viewscreens shall be gas-tight to maintain air conditions internally and shall be tested for leak-tightness to U.S. Federal Class III standards.
- Sleeve-and-glove assemblies shall be single-piece. Glove assembly shall allow for replacement or change out without breaking containment.
- Stainless steel gloveports with one-piece sleeve-and-glove assembly shall be built directly into the viewscreen for improved visibility and ergonomics.
- Gaskets shall use solid, closed-cell silicone.
- External micro-bulb light assembly shall provide 75 foot-candles of illumination to the work surface and shall be serviceable from outside the cabinet.
- Tubular stand constructed from Type 304 stainless steel shall be provided.
- Two internal duplex outlets (each 115V, 60Hz) with weather-proof covers shall be provided in the primary working chamber. Outlets shall be switched from outside the glovebox.
- The stainless steel drain pan shall be sloped to allow efficient drainage of liquids through a 1/2" stainless steel locking ball valve.
- Built-in digital readout magnehelic gauges shall be provided to monitor proper operating pressures. Audible and visual alarms shall be provided.

## Warranty

The Baker Company Inc., expressly represents and warrants all goods (a) to be as specified (and described) in The Baker Company catalogs and literature, and (b) to be free under normal use, service and testing (all as described in The Baker Company catalogs and literature) from defects in material and workmanship for a period of twelve months from the invoice date. The exclusive remedy for any breach or violation of this warranty is as follows: The Baker Company, Inc., will F.O.B. Sanford, Maine, furnish without charge repairs to or replacement of the parts or equipment which proved defective in material or workmanship. No claim may be made for any incidental or consequential damages.

THIS WARRANTY IS EXPRESSLY IN LIEU OF ALL OTHER WARRANTIES, EXPRESSED OR IMPLIED, INCLUDING ANY IMPLIED WARRANTY OF MERCHANTABILITY OR FITNESS FOR A PARTICULAR PURPOSE UNLESS OTHERWISE AGREED IN WRITING SIGNED BY THE BAKER COMPANY. (THE BAKER COMPANY SHALL NOT BE RESPONSIBLE FOR ANY IMPROPER USE, INSTALLATION, SERVICE OR TESTING OF THE GOODS.)

Specifications subject to change without notice.

# THE BAKER COMPANY

P.O. Drawer E, Sanford, Maine 04073 (207) 324-8773 1-800-992-2537 FAX (207) 324-3869 [www.bakerco.com](http://www.bakerco.com)

©2004 The Baker Company