

# Swirl Diffusers

- Type FDE
- with fixed air control blades for high volume flow rates

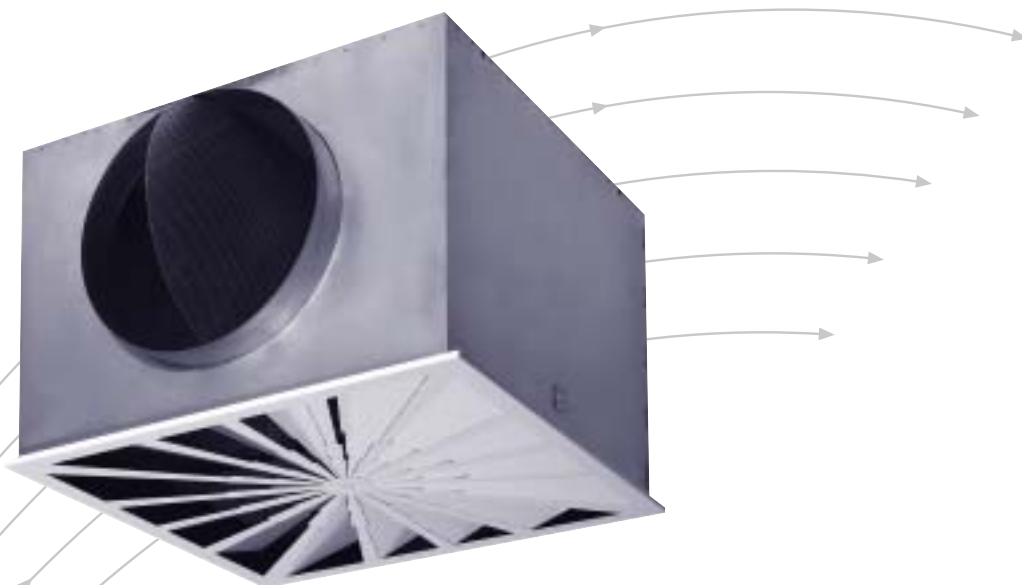

**TROX<sup>®</sup> TECHNİK**

• Gebrüder Trox GmbH  
• Heinrich-Trox-Platz  
• D-47504 Neukirchen-Vluyn

Telephone +49/28 45/2 02-0  
Telefax +49/28 45/2 02-2 65  
e-mail trox@trox.de  
www.troxtechnik.com

# Contents · Description · Materials

Description	2
Materials	2
Construction · Dimensions · Installation	3
Nomenclature	4
Acoustic Data	4
Aerodynamic Data	5
Order Details	6



**Type FDE**

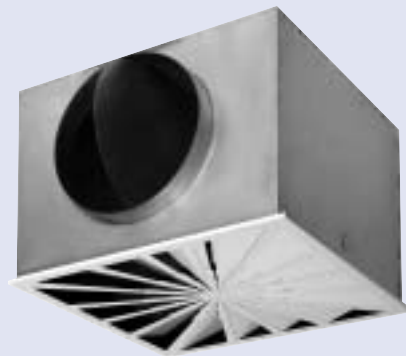

**Type FDE-...-H (with plenum box)**



## Description

Type FDE swirl diffusers as supply or extract air units are particularly suitable for comfort areas like office and department stores.

The horizontal swirl type discharge of supply air ensures high induction and hence rapid reduction in jet velocity and temperature differential.

The air diffusers are suitable for supply air temperature differentials in the range of +10K to -10K and room heights from 2.80 m.

Swirl diffusers type FDE consist of the square face plate with continuous rear perimeter seal, fixed radially arranged air control blades and the rear frame. The supply air construction also contains a perforated plate mounted on the rear frame to optimise the air distribution. To obtain low sound power levels especially at high volume flow rates, the triangular shaped, angled air control blades extend into the corners of the square diffuser.

The plenum box is supplied with side entry spigot. Volume control damper and/or lip seal are available on request.

## Materials

Swirl diffuser and rear frame with perforated plate are made of galvanised sheet steel. The standard finish of the swirl diffuser is powder-coated white (RAL 9010, gloss level 50 %), any other RAL colour on request (gloss level 70 %) (RAL 9006, gloss level 30 %). Rear frame and perforated plate are powder-coated black (RAL 9005). The plenum box is made of galvanised sheet steel, the lip seal is of rubber.

# Construction · Dimensions · Installation

## Constructions · Dimensions

Size	Plenum box	ØD	H	□K	□Q
600/625	AK004	248	345	567	Size
600/625	AK011	313	410	567	-2 mm

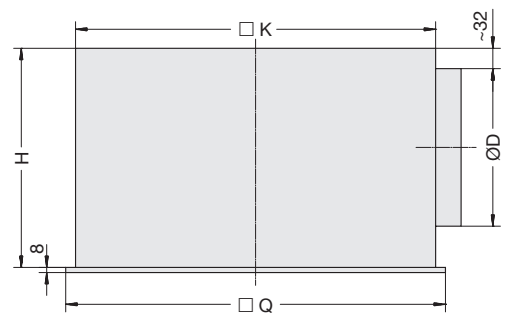
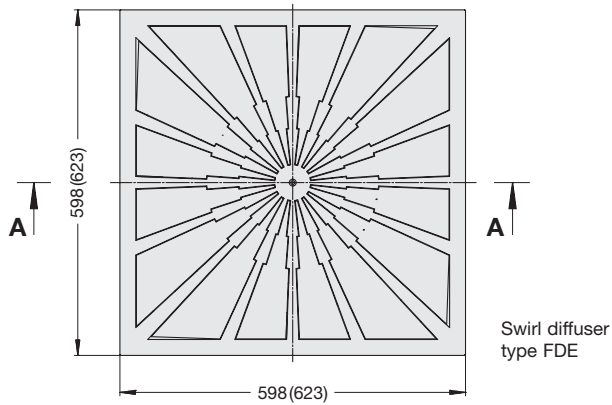

FDE with plenum box

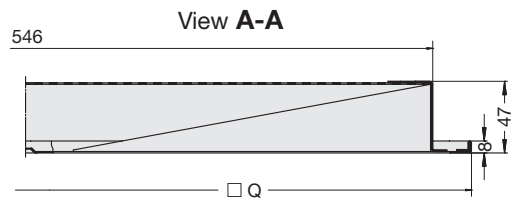

## Installation

### Surface mounting on ceiling

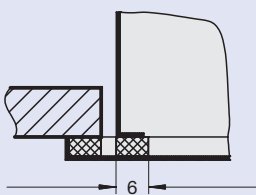
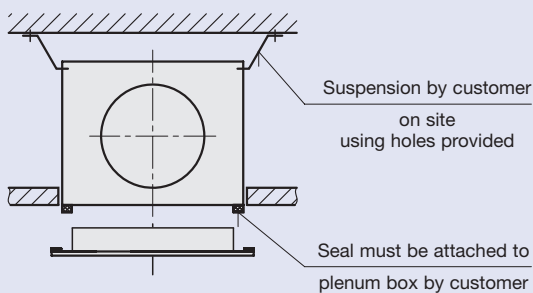

Fixing the diffuser face using centre screw

### Installation flush to ceiling



### Installation with cut out in ceiling

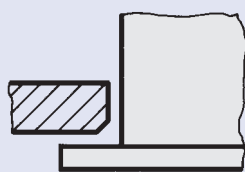

Type FDE swirl diffusers are suitable for flush installation in the ceiling. The plenum box is suspended by wires or slotted strips using the drilled holes provided in the plenum. A self adhesive seal, supplied loose, must be fitted to the plenum box by the client. The diffuser face is fitted to the plenum box by means of a centre fixing screw located in a cross channel in the plenum box. The head of the fixing screw is covered by a decorative cap.

## Measuring the Reference Pressures

For simple adjustment of the volume flow, on request the plenum box can be provided with a test connection for measurement of a reference pressure and a volume control damper operated by sheathed cables. The characteristic curve of pressure reading versus volume flow rate for each size of plenum box is supplied.

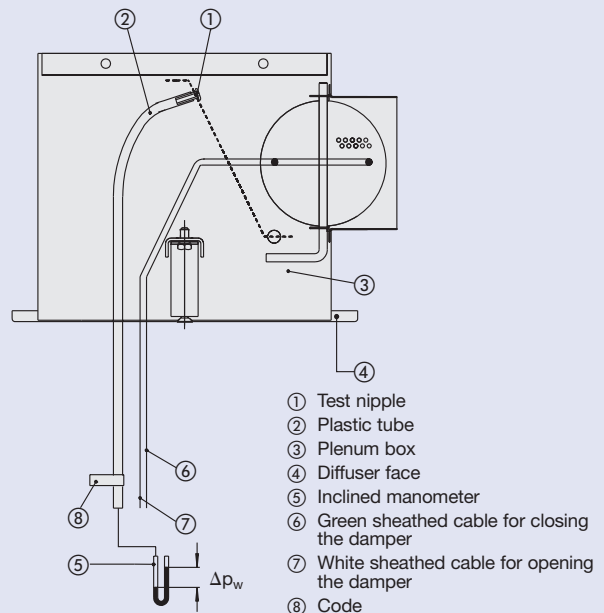

- ① Test nipple
- ② Plastic tube
- ③ Plenum box
- ④ Diffuser face
- ⑤ Inclined manometer
- ⑥ Green sheathed cable for closing the damper
- ⑦ White sheathed cable for opening the damper
- ⑧ Code

# Nomenclature · Acoustic Data

## Nomenclature

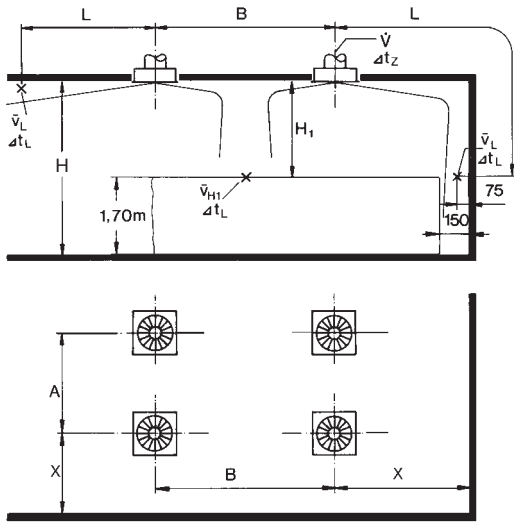

- $\dot{V}$  in l/s (m<sup>3</sup>/h): Volume flow rate per diffuser
- A, B in m: Spacing between two diffusers
- L in m: Distance horizontal + vertical (X + H<sub>1</sub>) when discharging towards the wall
- X in m: Distance from centre of diffuser to the wall
- H<sub>1</sub> in m: Distance between ceiling and occupied zone
- A<sub>eff</sub> in m<sup>2</sup>: Effective outlet area 0.04467 m<sup>2</sup> (supply air)
- $\bar{v}_L$  in m/s: Max. time average air velocity at the wall
- $\bar{v}_{H1}$  in m/s: Max. time average air velocity between two diffusers at distance H<sub>1</sub> from the ceiling
- Δt<sub>Z</sub> in K: Temperature difference between supply air and room air
- Δt<sub>L</sub> in K: Difference between core and room temperature at distance L = A/2 or B/2 + H<sub>1</sub> or L = X + H<sub>1</sub>
- Δp<sub>t</sub> in Pa: Total pressure drop
- L<sub>WA</sub> in dB(A): A-weighted sound power level
- L<sub>WNC</sub>: NC rating of sound power level
- L<sub>WNR</sub>: L<sub>WNR</sub> = L<sub>WNC</sub> + 2
- L<sub>pA</sub>, L<sub>pNC</sub>: A-weighting and NC rating respectively of room sound pressure level
  - L<sub>pA</sub> ~ L<sub>WA</sub> -8 dB
  - L<sub>pNC</sub> ~ L<sub>WNC</sub> -8 dB
- α in °: Damper angle

**1** Sound power level and pressure drop  
Type FDE-A (extract air)

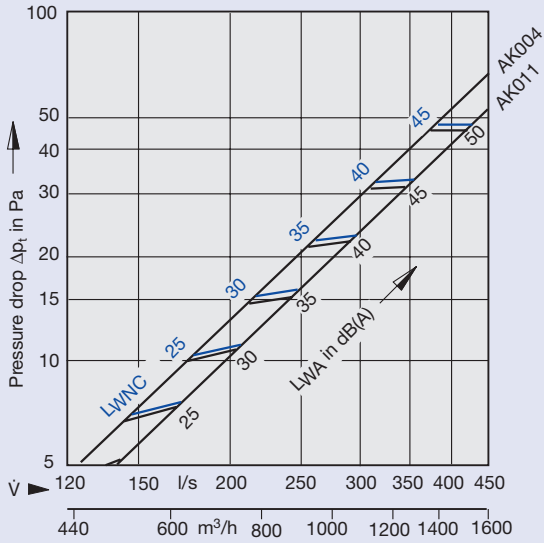

Correction to diagram 1: Volume control damper setting  
Plenum box AK004

FDE-A	45°	90°
Δp <sub>t</sub>	x2	x5.2
L <sub>WA</sub>	+5	+11
L <sub>WNC</sub>	+5	+10

Correction to diagram 1: Volume control damper setting  
Plenum box AK011

FDE-A	45°	90°
Δp <sub>t</sub>	x1.5	x3.5
L <sub>WA</sub>	+1	+5
L <sub>WNC</sub>	+1	+5

**2** Sound power level and pressure drop  
Type FDE-Z (supply air)

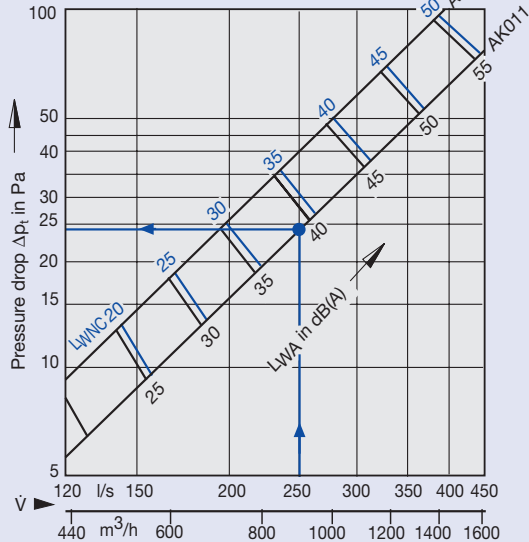

Correction to diagram 2: Volume control damper setting  
Plenum box AK004

FDE-Z	45°	90°
Δp <sub>t</sub>	x1.6	x3.4
L <sub>WA</sub>	+5	+11
L <sub>WNC</sub>	+10	+17

Correction to diagram 2: Volume control damper setting  
Plenum box AK011

FDE-Z	45°	90°
Δp <sub>t</sub>	x1.3	x2.6
L <sub>WA</sub>	+2	+5
L <sub>WNC</sub>	+2	+5

## Example

Data given:

A room (10 x 10 m) to be equipped with 4 FDE-Z-H/625 x 313 square difusers with spacing 5 m between the difusers and 2.5 m to the wall. The difusers are mounted at 3.6 m height, i.e. 1.9 m above the occupied zone. The air change rate has to be 10 per hour. The room attenuation is 8 dB.

In the cooling mode the supply air temperature is -10K.

Questions:

Is this possible with acceptable noise levels and comfort criteria?  
What is the pressure drop created by the difusers?

Procedure / results:

$\dot{V}_{tot} = 10 \text{ m} \cdot 10 \text{ m} \cdot 3.6 \text{ m} \cdot 10 \text{ h}^{-1} = 3600 \text{ m}^3/\text{h}$   
per diffuser  $\dot{V} = 900 \text{ m}^3/\text{h}$  (250 l/s)

Diagram 2 (page 4):

$L_{WA} = 39 \text{ dB(A)}$ ,  $\Delta p_t = 24 \text{ Pa}$

Sound pressure level in the room  $L_{pA} = 39 \text{ dB(A)}$   
+ 6 dB(A) (increase for 4 difusers)

-8 dB(A) (room attenuation)

= 37 dB(A)

Acceptable noise level

Diagram 5:

$A = 5 \text{ m}$  and  $\dot{V} = 900 \text{ m}^3/\text{h}$

$H_1 = 3.6 \text{ m} - 1.7 \text{ m} = 1.9 \text{ m}$

$\bar{v}_{H1} = 0.12 \text{ m/s}$

Acceptable comfort conditions

Diagram 6:

$L = X + H_1 = 2.5 \text{ m} + 1.9 \text{ m} = 4.4 \text{ m}$

$\bar{v}_L = 0.23$

$\Delta t_L / \Delta t_z = 0.072$

$\Delta t_L = 0.072 \cdot (-10\text{K}) = -0.72\text{K}$

The air velocity in the occupied zone at a distance of 0.5 m from the wall is approx.  $0.5 \cdot \bar{v}_L = 0.12 \text{ m/s}$

**3** Air velocity, diffuser arrangement more than one row, if  $B = 4.0 \text{ m}$

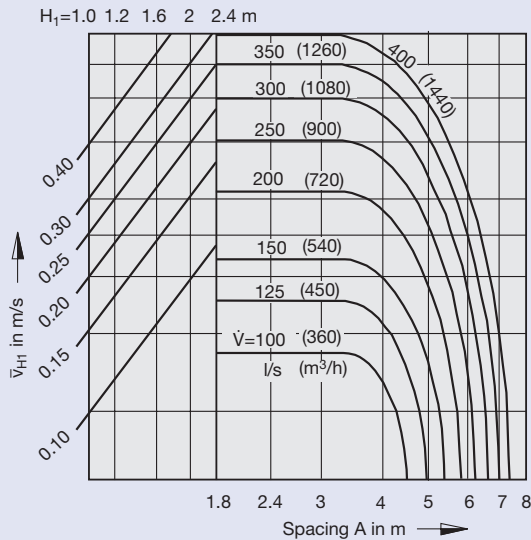

**5** Air velocity and temperature quotient at the wall

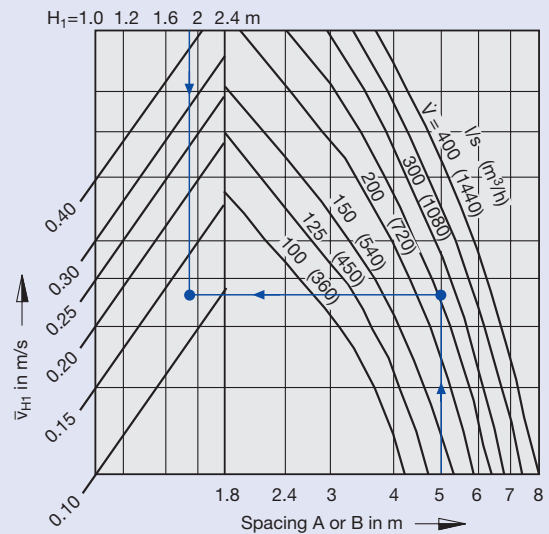

**4** Air velocity, diffuser arrangement single row or more than one row, if  $B \geq 6.0 \text{ m}$

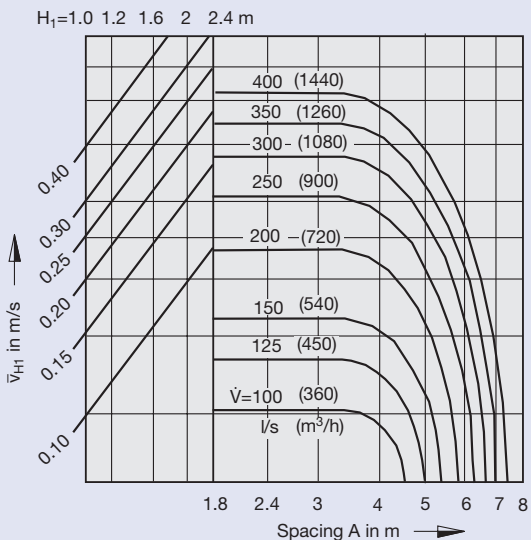

**6** Air velocity with square arrangement of diffusers ( $A = B$ )

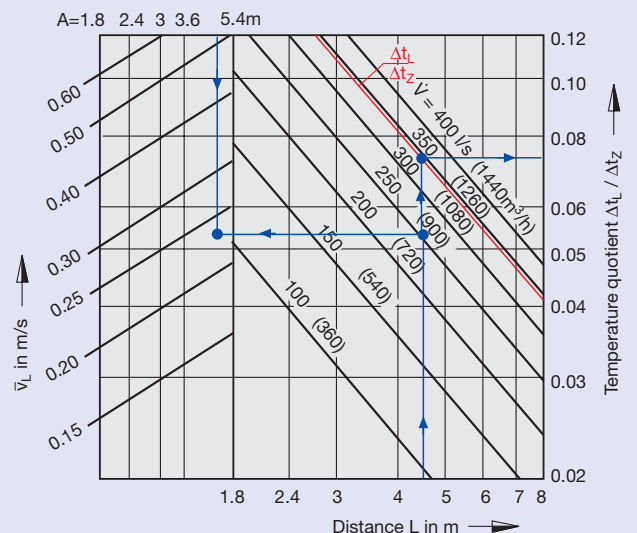

# Order Details



## Specification text

Type FDE swirl diffuser with square face and fixed air control blades for swirling horizontal discharge with high induction. Diffuser face consists of angled triangular shaped blades which extend into the corners includes a rear mounted frame complete with perforated plate to optimise the air distribution.

Type FDE swirl diffuser is supplied with plenum box and – on request – with damper and/or lip seal.

Also on request to measure the reference pressure the plenum can be provided with a sheathed cable adjusted volume control damper and measuring nipple.

The diffuser face is fitted and removed by means of a central screw into a channel section in the plenum.

## Materials

Diffuser face and rear frame with perforated plate are made of galvanized sheet steel.

The surfaces are pre-treated (ET-L grey-white RAL 9002) and powder-coated white (RAL 9010, gloss level 50 %), or, if required, any other RAL colour (gloss level 70 %) (RAL 9006, gloss level 30 %). Rear frame and perforated plate are powder-coated black (RAL 9005).

The plenum box is made of galvanised sheet steel, the lip seal is of rubber.

## Order Code

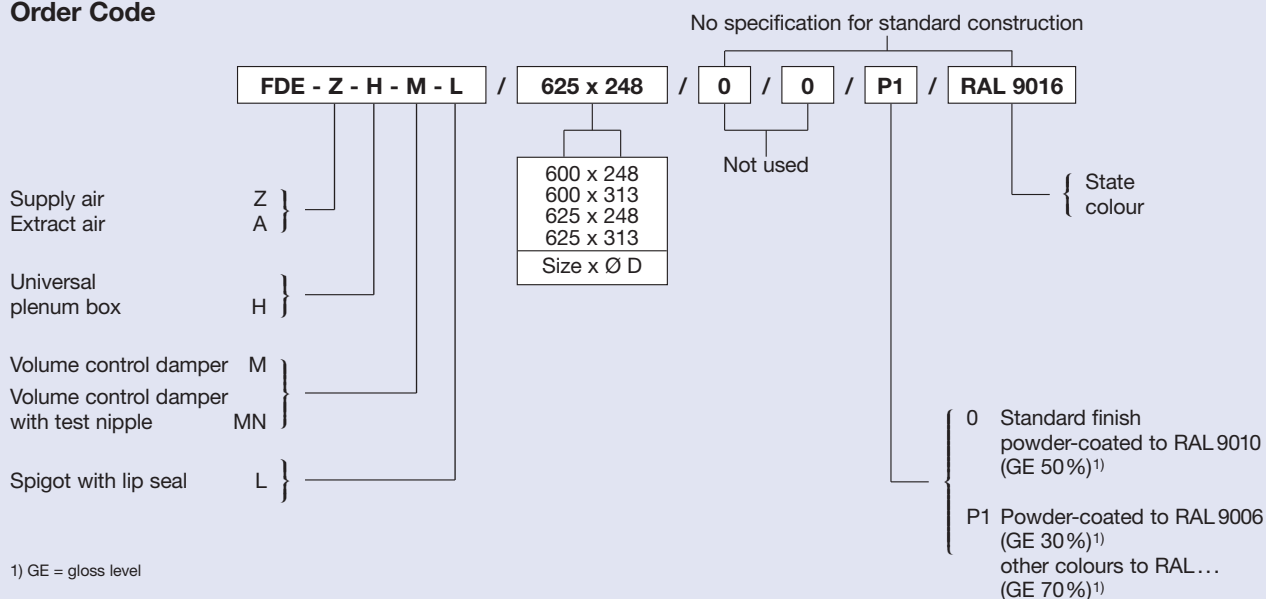

## Order example

Make: TROX  
Type: FDE-Z-H-M-L / 625 x 248 / P1 / RAL 9016